

Order #XXXXX - ECO-8C Sustainable Podium

| Panel | Description |
|-------|----------------------------------|
| 1 | 42" 90° Connector |
| 2 | 6" x 42" Panel |
| 3 | 42" 90° Connector |
| 4 | 18" x 42" Panel w/ 38" Connector |
| 5 | 42" 90° Connector |
| 6 | 6" x 42" Panel |
| 7 | 42" 90° Connector |
| 8 | 18" x 42" Panel w/ 38" Connector |
| 9 | 6.248" x 38" Panel |
| 10 | 38" 90° Connector |
| 11 | 22" x 38" Panel w/Door |
| 12 | 38" 90° Connector |
| 13 | 18" x 38" Panel |
| 14 | 38" 90° Connector |
| 15 | 22" x 38" Panel |
| 16 | 38" 90° Connector |
| 17 | 38" 180° Connector |

Steps:

- 1) Assemble the panels in numerical order as shown below.
- 2) Attach the EcoGlass sign with stand-off barrels and screw caps.
- 3) Affix Shelf Supports inside pedestal assembly; place Shelf onto supports.
- 4) Place counter tops on assembled pedestals.

See *General Setup Instructions for Panel Systems* on General Instructions page.

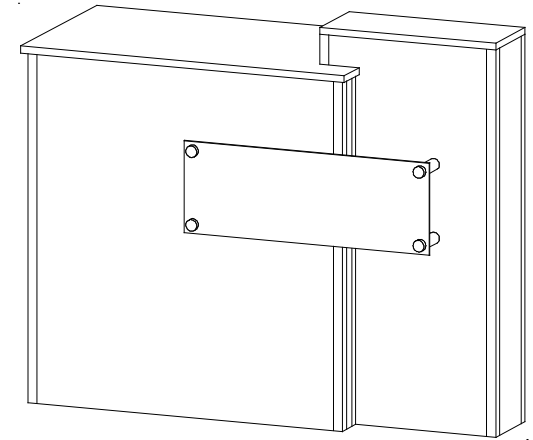
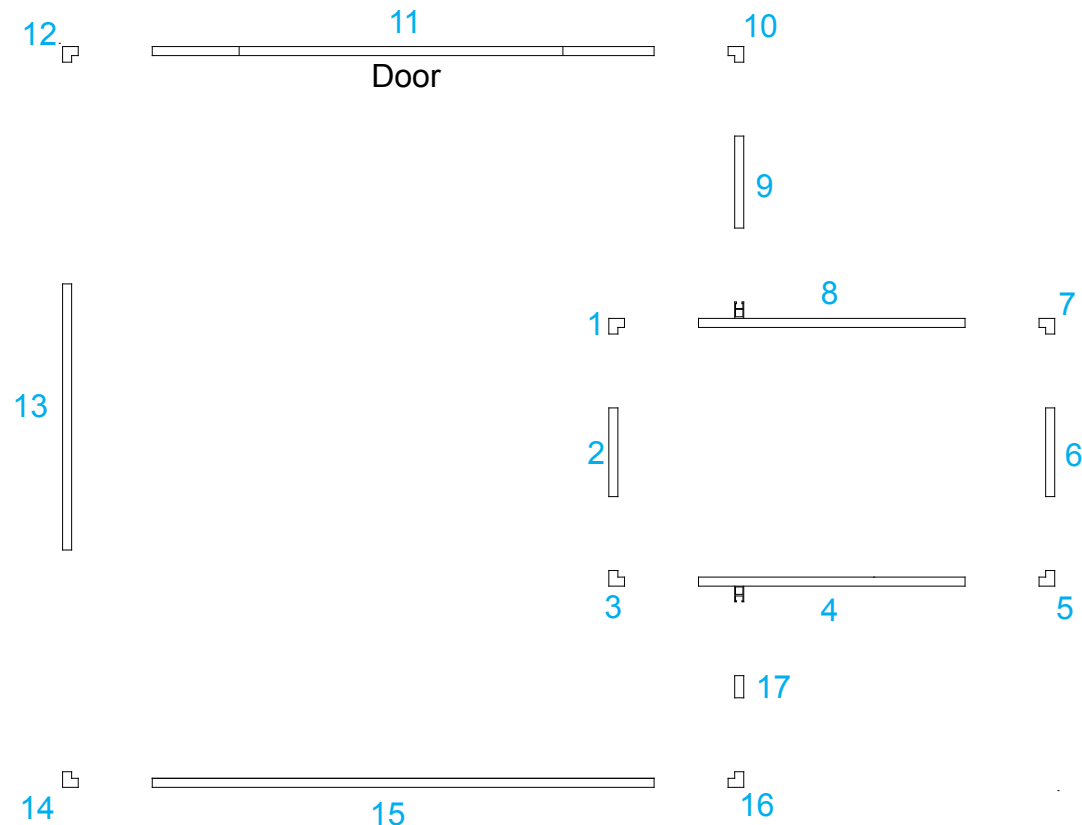
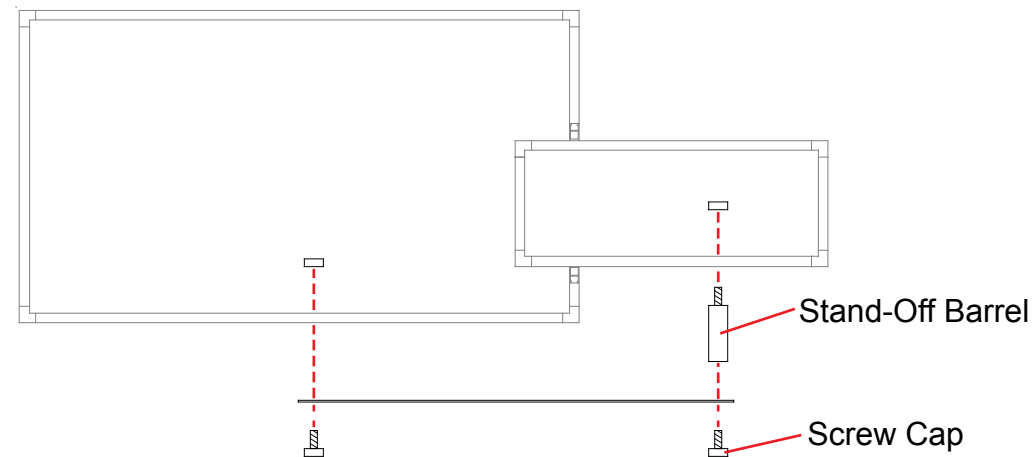

When assembled

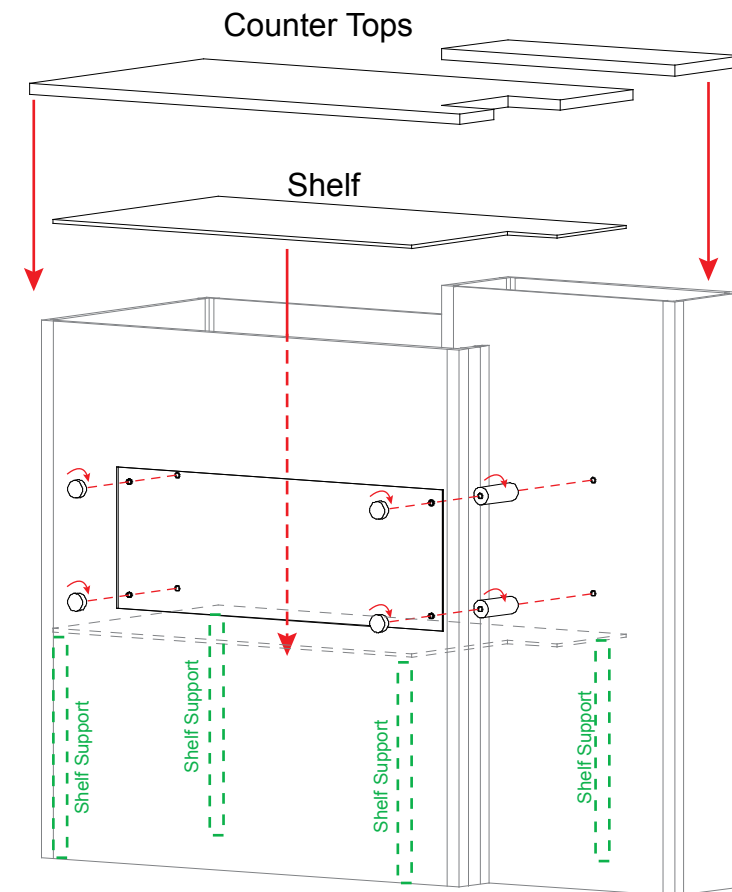

ecosystems™

SUSTAINABLE EXHIBITS

YOUR BRAND. YOUR DESIGN. YOUR PLANET.

General Setup Instructions for ECO Panel System

Using Your Setup Instructions

The Setup Instructions are created specifically for your configuration. They are laid out sequentially in levels, including exploded views, and a logical series of detailed steps to assemble the main structure and components. We encourage you to study the instructions before attempting to assemble your exhibit.

Each page reminds you to tighten the setscrews after disassembling your exhibit to prevent loss of the locks and setscrews (see below in RED). This is VERY IMPORTANT.

Cleaning and Packing Your Display

- 1) Use care when cleaning aluminum extrusion or Eco Glass inserts. Use only non-abrasive cleaners.
- 2) When cleaning laminate inserts, countertops, or panels use mild cleansers and a soft material such as cotton.
- 3) Keep all display components away from extreme heat and long exposure to sunlight to avoid warping and fading.
- 4) Retain all packing material. It will make re-packing much easier and will reduce the likelihood of shipping damage. Each Layer will be labeled with the packing order.

General Setup Instructions for Extrusion System



Most exhibits can be assembled with the supplied Hex Key Tool. Occasionally, other tools may be needed.



Most horizontal extrusion connections have a patented expandable lock. This lock inserts into the groove of an opposing extrusion. Tightening the lock with the Hex Key Tool expands the lock and creates a strong positive connection.

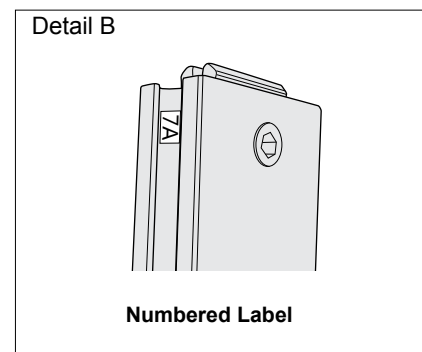

Each extrusion contains a numbered label which corresponds with setup instructions. The label is located within a groove of the extrusion (when possible). With extrusion components the labels contain Black numbers unless otherwise specified.

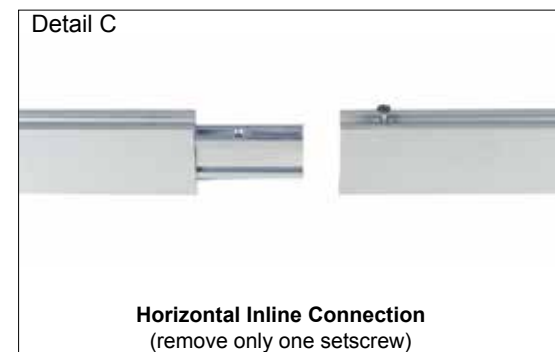

Remove only (1) setscrew when disassembling. Replace setscrew in extrusion after assembling it. Before packing, replace setscrew in extrusion to avoid losing it.

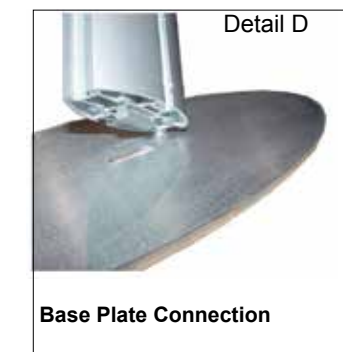

Attach base plate to vertical extrusion using the lock provided. Place base plate on ground and set vertical post/lock in base plate slot. Tighten lock with Multi-tool.

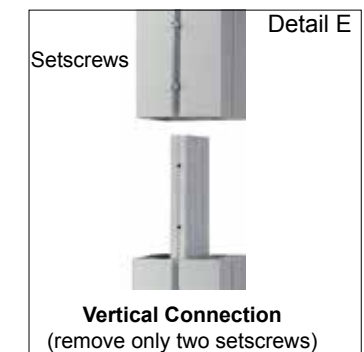

When vertical extrusions are packed in portable cases rather than crates or tubs, they must be broken down into smaller sections which then require assembly.

Remove only (2) setscrews when disassembling. Replace setscrews in extrusion after assembling it. Before packing, replace setscrews in extrusion to avoid losing them.

WHEN DISASSEMBLING ALUMINUM EXTRUSION, TIGHTEN ALL SETSCREWS AND LOCKS TO PREVENT LOSS DURING SHIPPING

FOR LOST PAGES OR MISSING SETUPS PLEASE GO ONLINE TO THE BOTTOM SEARCH BAR OF THE HOME PAGE ON WWW.ECOSYSTEMSDISPLAYS.COM AND TYPE IN THE JOB NUMBER LOCATED ON THE PACKING PAGES

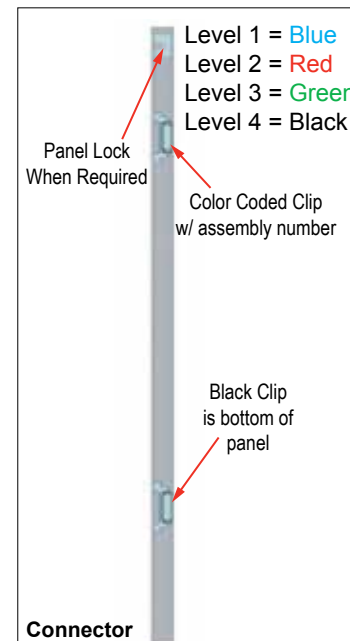

Each component has 2 clips, the lower clip is ALWAYS black. The top clip is color coded to distinguish the level. The color coded clip also contains the numbered label.

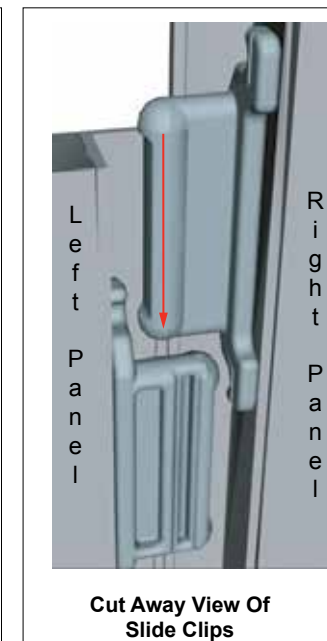

Components connect together by aligning them and sliding downward connecting clips together.

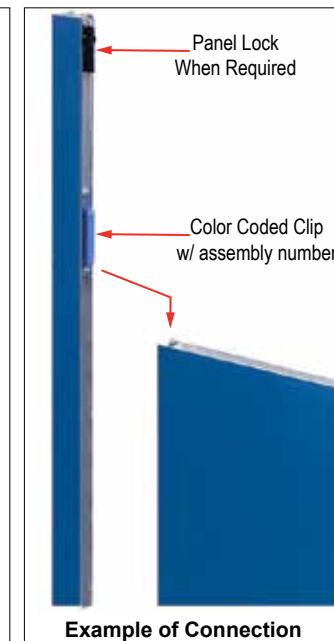

Configurations are assembled from left to right, usually starting with #1 and following the numbered sequence.

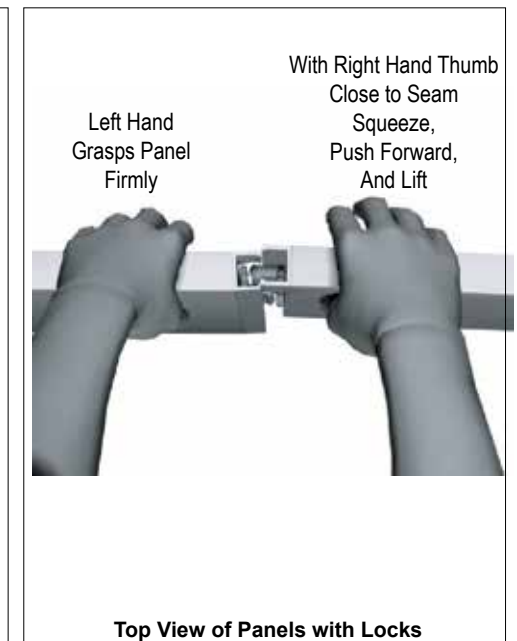

The first level of components contains panel locks that are located at the top of the panel for extra stability and a seamless connection. When disassembling panels, twist top connection slightly and lift right panel upward.