

Plan View

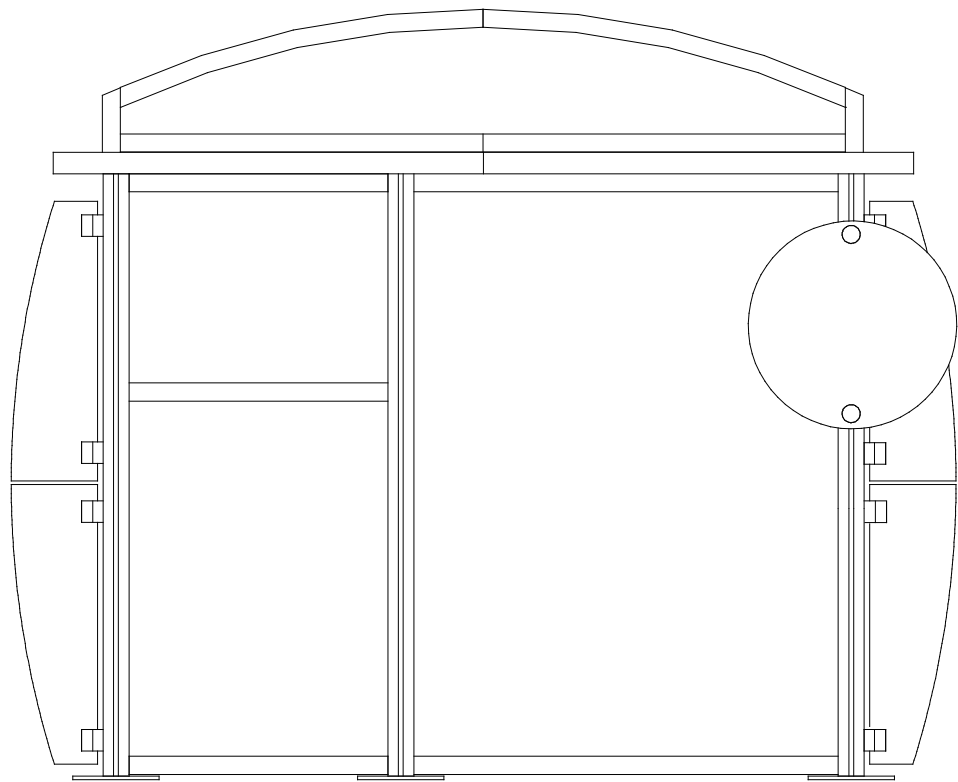

Front View

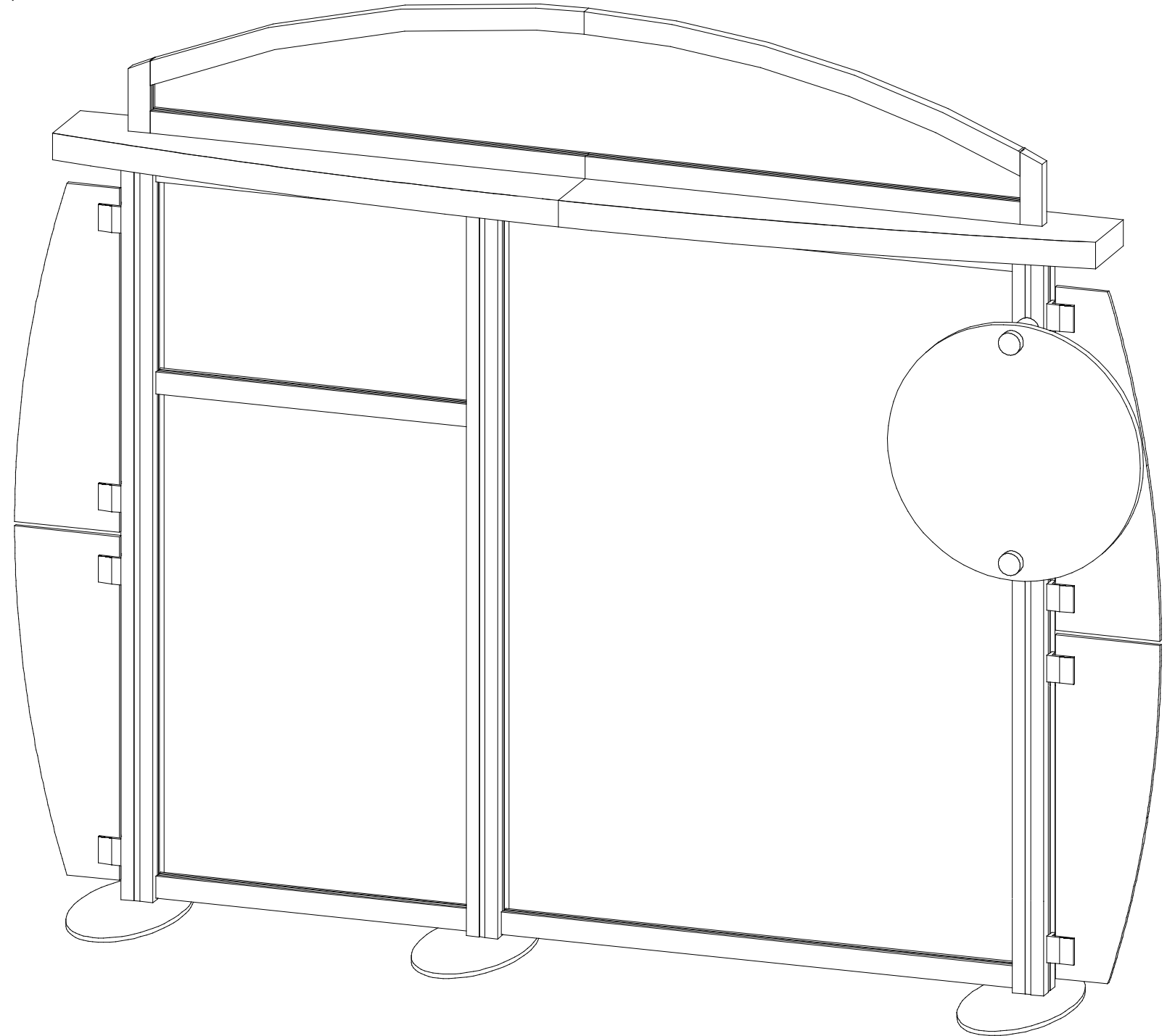

WHEN DISASSEMBLING ALUMINUM EXTRUSION, TIGHTEN ALL SETSCREWS AND LOCKS TO PREVENT LOSS DURING SHIPPING

visionary™ IDESIGNS

Using Your Setup Instructions

The Visionary Designs Setup Instructions are created specifically for your configuration. They are laid out sequentially, including an exploded view of the entire display, and then a logical series of detailed steps to assemble the main structure and components. We encourage you to study the instructions **before** attempting to assemble your exhibit.

Each page reminds you to tighten the setscrews after disassembling your exhibit to prevent loss of the locks and setscrews (see below in RED). This is **VERY IMPORTANT**.

Cleaning and Packing Your Display

- 1) Use care when cleaning aluminum extrusion or acrylic inserts. Use only non-abrasive cleaners.
- 2) When cleaning laminate inserts or countertops, use mild cleansers and a soft material such as cotton.
- 3) Keep all display components away from extreme heat and long exposure to sunlight to avoid warping and fading.
- 4) Retain all packing material. It will make re-packing much easier and will reduce the likelihood of shipping damage.



The Tool

Most Visionary Designs exhibits can be assembled with the supplied Hex Key Tool. Occasionally, a flat head screwdriver may be required.



Typical Connection

Most horizontal extrusion connections have a patented expandable lock. This lock inserts into the groove of an opposing extrusion. Tightening the lock with the Hex Key Tool expands the lock and creates a strong positive connection.



Typical Connection (cont'd)

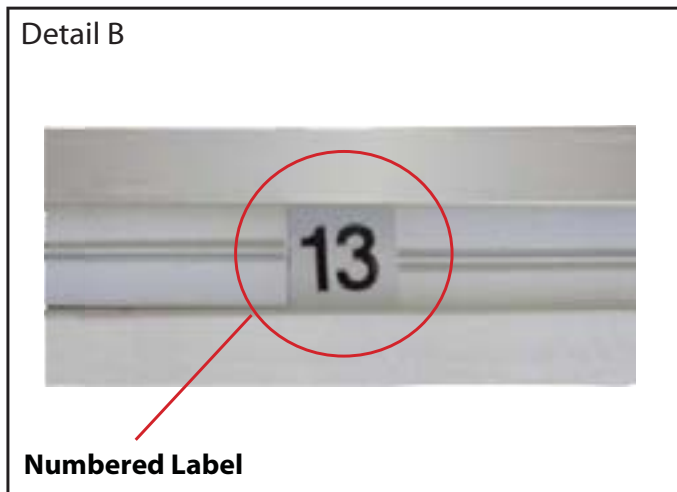

Detail B

Numbered Label

Each extrusion contains a numbered label which corresponds with setup instructions. The label is located within a groove of the extrusion (when possible). With Visionary Designs the labels contain Black numbers unless otherwise specified.



Detail C

Horizontal Inline Connection (remove only one setscrew)

Remove only (1) setscrew when disassembling. Replace setscrew in extrusion after assembling it. Before packing, replace setscrew in extrusion to avoid losing it.

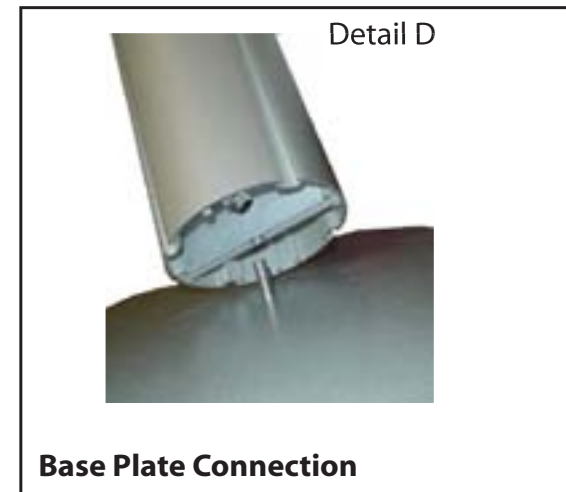

Detail D

Base Plate Connection

Attach base plate to round or square vertical extrusion using the bolt provided. Be careful not to strip the threads.

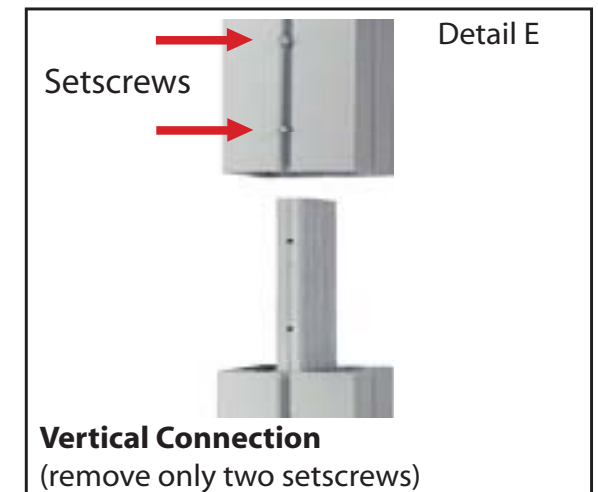

Detail E

Vertical Connection
(remove only two setscrews)

When vertical extrusions are packed in portable cases rather than crates or tubs, they must be broken down into smaller sections which then require assembly.

Remove only (2) setscrews when disassembling. Replace setscrews in extrusion after assembling it. Before packing, replace setscrews in extrusion to avoid losing them.

WHEN DISASSEMBLING ALUMINUM EXTRUSION, TIGHTEN ALL SETSCREWS AND LOCKS TO PREVENT LOSS DURING SHIPPING

866.652.2100

Item	Qty.	Description
1	3	Oval Base Plate
2	1	42h Square Vertical Extrusion w/ Canopy Attachment
3	1	42" Square Vertical Extrusion w/ Canopy Attachment
4	1	42" Square Vertical Extrusion w/ Canopy Attachment
5	2	29.5" Horizontal Extrusion w/ Velcro attached
6	2	18" Horizontal Extrusion

- Steps:
- 1) Attach lower vertical extrusions [2, 3 and 4] to oval base plates [1], see detail D on general information page.
 - 2) Attach horizontal extrusions [5] between vertical extrusions [2 and 3], see illustration below for extrusion orientation.
 - 3) Attach horizontal extrusions [6] between vertical extrusions [3 and 4].
 - 4) Apply graphics as indicated.

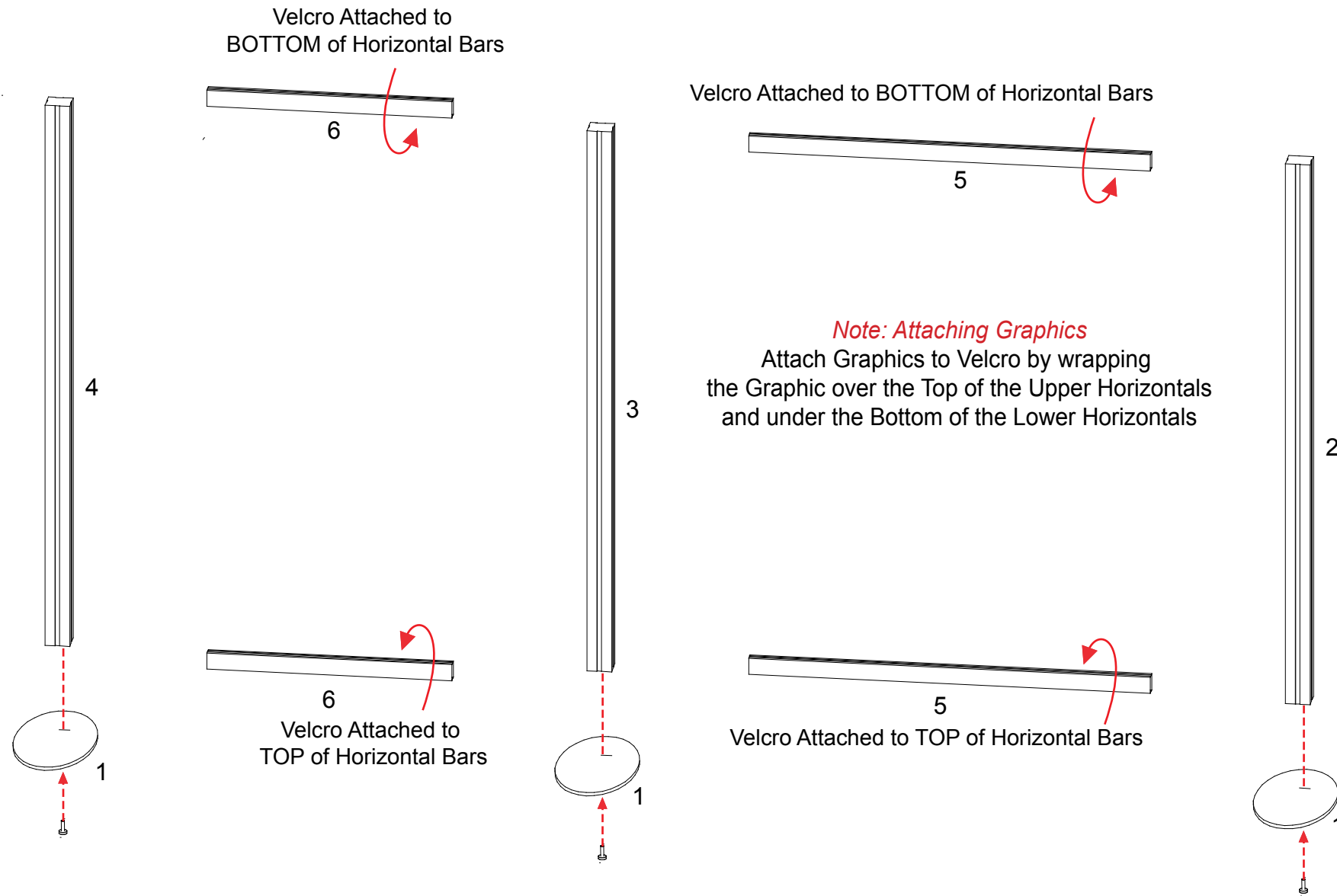
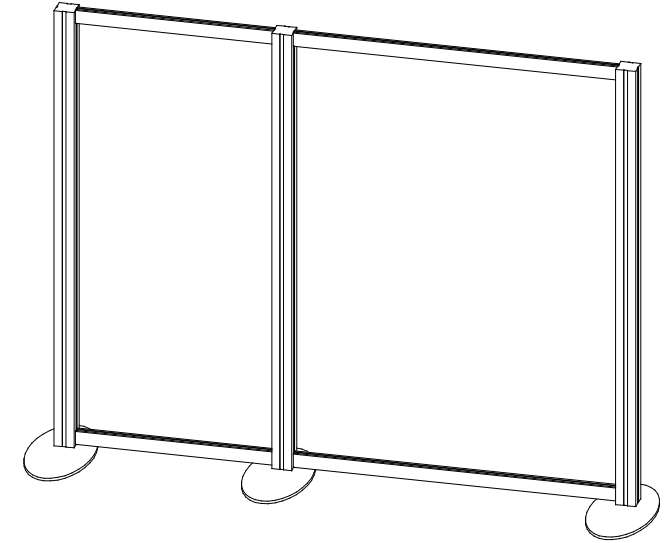

WHEN DISASSEMBLING ALUMINUM EXTRUSION, TIGHTEN ALL SETSCREWS AND LOCKS TO PREVENT LOSS DURING SHIPPING

866.652.2100

Item	Qty.	Description
8a/8b	1	24.938" w Horizontal Extrusion
9a/9b	1	Curved Horizontal Extrusion
10	1	4.08" h Vertical Extrusion
11	1	4.08" h Vertical Extrusion

Steps

- 1) Attach 2-piece ceiling to top of assembled table top frame using bolts as shown.
- 2) Connect horizontal extrusions [8a to 8b and 9a to 9b] together.
- 3) Attach horizontal assembly [8a/8b] to top of ceiling using bolts supplied.
- 4) Attach vertical extrusions [10 and 11] to left and right side of horizontal [8a/8b].
- 5) Place inserts
- 6) Attach curve horizontal assembly [9a/9b] between verticals [10 and 11] and atop inserts.
- 7) (Optional) Attach Round Sign using standoff barrels and caps.
- 8) Attach wings using A10 clamps as shown.

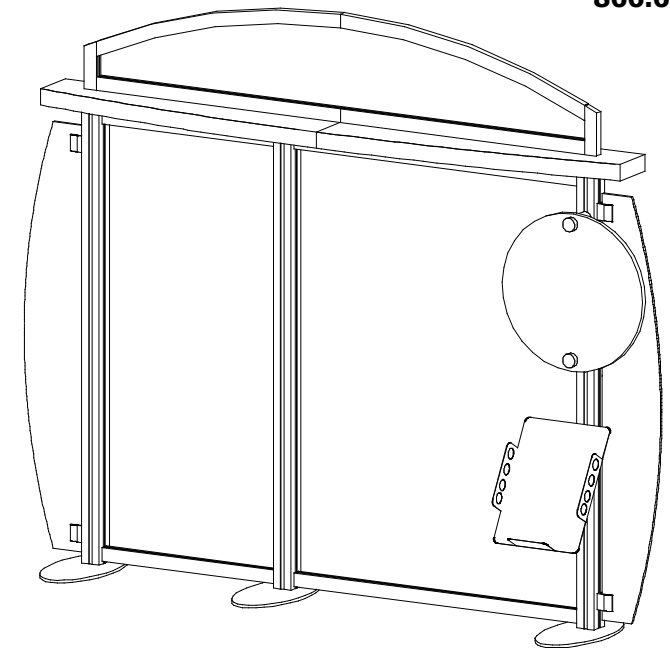

Note: Attaching Graphics
Velcro Graphic to BACK of Upper and Lower Horizontal Bars.

Wing Attachment

Slide A10 Clamp into groove of square extrusion.

A10

When desired location is found, tighten set screw to secure.

Set-Screw

Tighten black plastic set screw to secure Wing in place.

Black Plastic Set-screw

*** Literature Rack Attachment**

Tighten Lock to Secure

Attach connector piece to rack as shown. Then connect assembled literature rack to vertical extrusion.

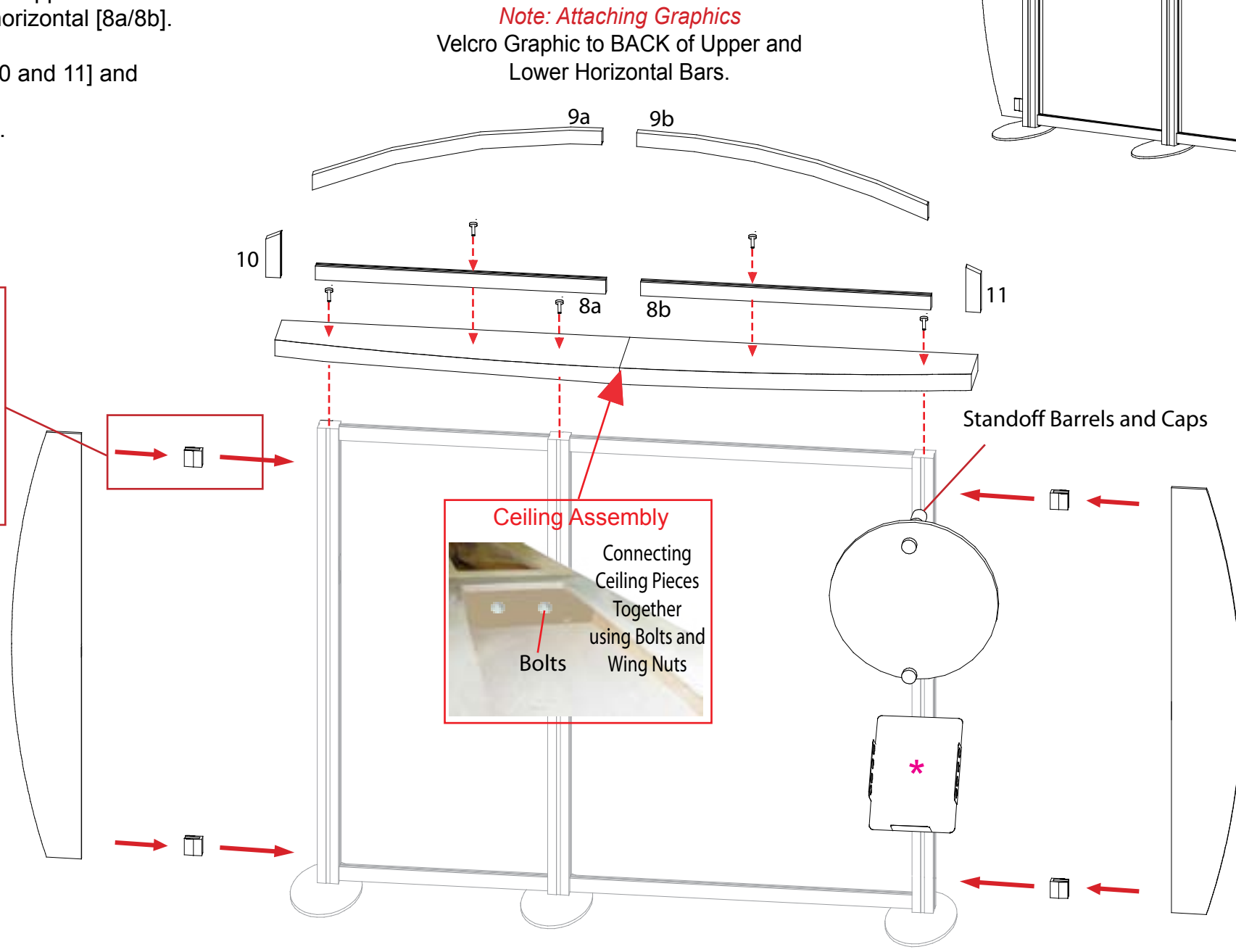

Sign Attachment (Optional)

stand off barrel

Slide stand off barrels into groove of backwall extrusion

Secure Sign to stand off barrels using stand off caps

WHEN DISASSEMBLING ALUMINUM EXTRUSION, TIGHTEN ALL SETSCREWS AND LOCKS TO PREVENT LOSS DURING SHIPPING

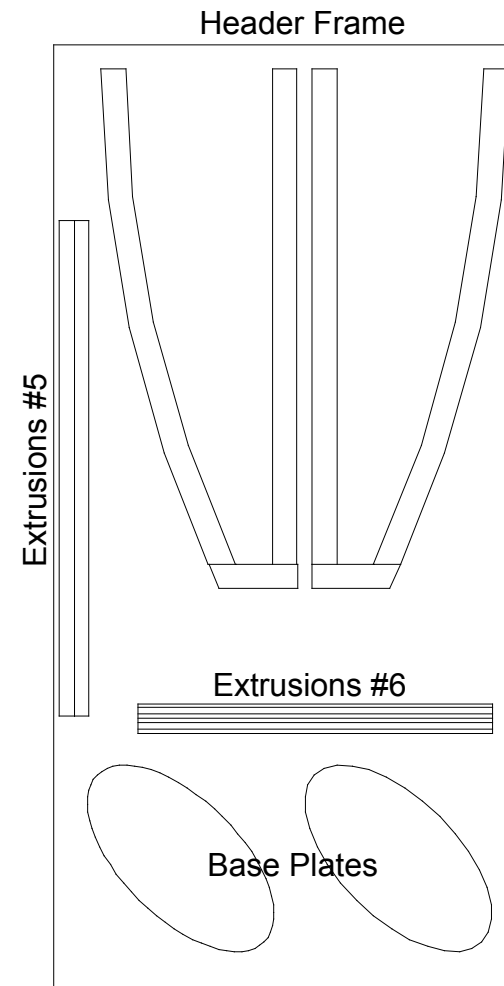
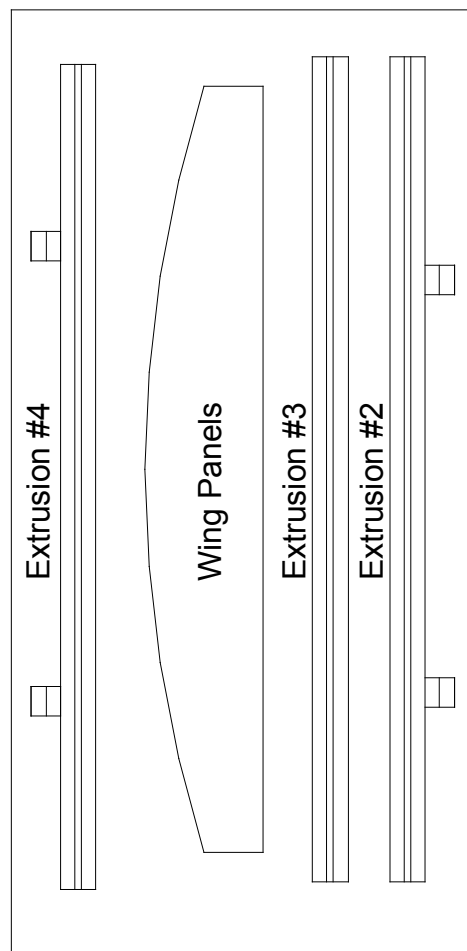
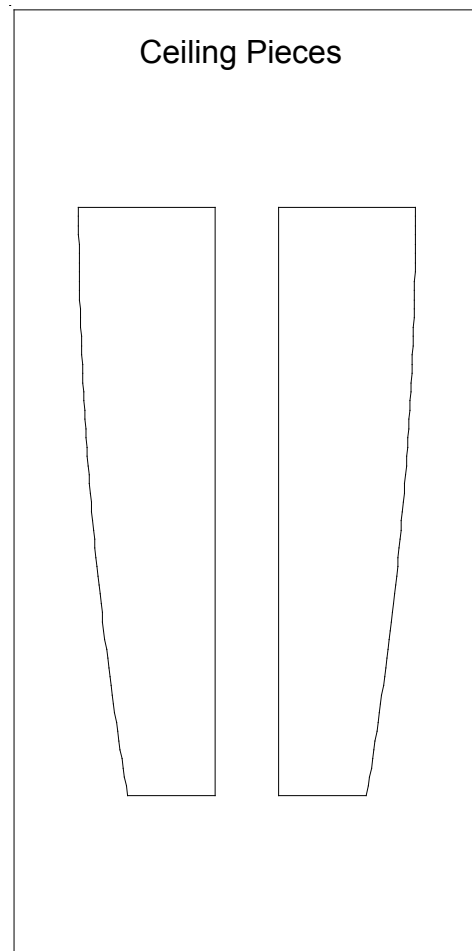

Additional Items:
- Setup Hardware
- Graphics

WHEN DISASSEMBLING ALUMINUM EXTRUSION, TIGHTEN ALL SETSCREWS AND LOCKS TO PREVENT LOSS DURING SHIPPING